

TX6BMW.E

8" 20cm 3-way Separate Speakers for BMW & Mini (Old versions, small midranges with small frames)



- Very easy to install thanks to the original BMW frames and the original BMW connectors.
- Nothing to cut, drill or solder
- Zero modification on the car.
- Breathtaking sound quality, largely beyond the original BMW Harman option.
- Amazing sound quality with big & low bass when just connected to the original BMW head-unit.
- Luxurious speakers equipped with neodymium magnets and treated paper cones.
- Ultra-shallow woofers (only 38mm thick) with reversed motor structure, grilles and protective fabrics to prevent dust in the gap.
- Comes with tweeter brackets and all necessary passive x-overs.

Dimensions

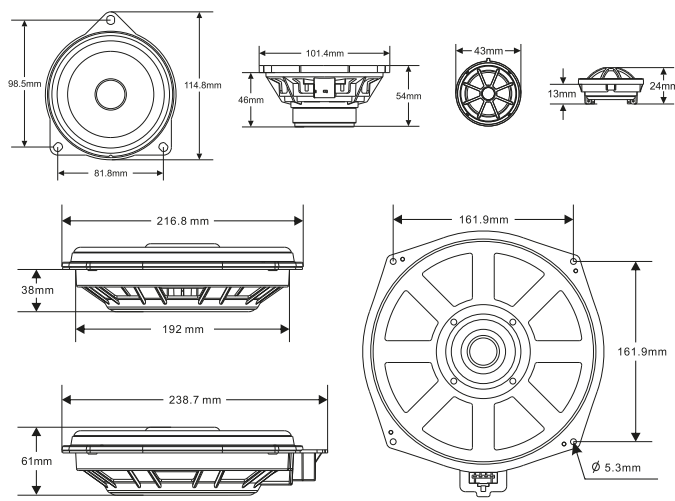

Connections

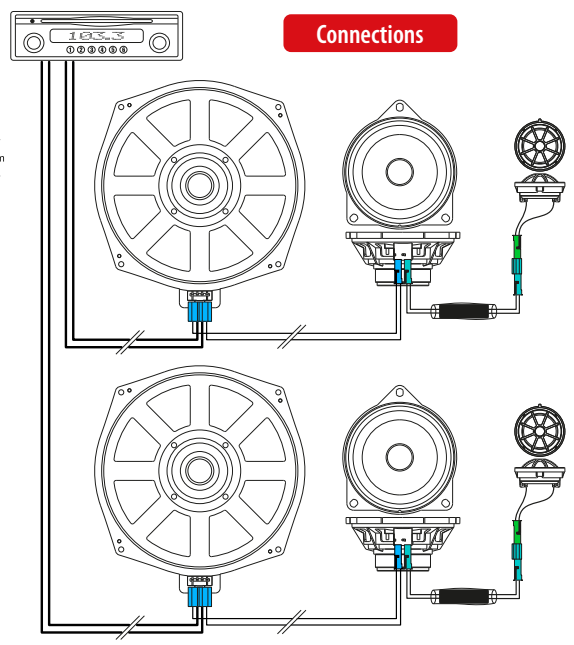

Compatibility

- BMW : E60 E61 E63 E64 E65 E66 E70 E71 E81 E82 E83 E84 E87 E88 E89 E90 E91 E92 E93 F01 F02 F07 F10 F11
- Mini : R60 R61

In the box

- 2x woofers
- 2x midranges
- 2x tweeters
- 2x tweeter supports
- 2x passive x-over (on line)

Specifications

- 3-way separate speakers
- Woofers
 - Diameter: 8" (20cm)
 - Magnet: Neodymium
 - Voice Coil Ø: 2" (50.8mm)
 - Impedance: 4Ω
 - Cone: composite paper
 - Frame: ABS + carbon
- Midranges
 - Diameter: 4" (10cm)
 - Magnet: Neodymium
 - Voice Coil Ø: 1" (25.4mm)
 - Impedance: 4Ω
 - Cone: composite paper
 - Frame: ABS + fiberglass
- Tweeters
 - Diameter: 1" (25mm)
 - Magnet: Neodymium
 - Voice Coil Ø: 1" (25.4mm)
 - Impedance: 4Ω
 - Cone: silk dome
 - Frame: ABS
- RMS power: 150W
- Peak power: 450W
- Sensitivity: 94.0dB/2.83v/1m
- Impedance: 4Ω
- Response: 22Hz - 25000Hz

