

## TX6BMW.F

8" 20cm 3-way Separate Speakers for BMW & Mini (New versions, large midranges with large frames)



Very easy to install thanks to the original BMW frames and the original BMW connectors.

Nothing to cut, drill or solder

Zero modification on the car.

Breathtaking sound quality, largely beyond the original BMW Harman option.

Amazing sound quality with big & low bass when just connected to the original BMW head-unit.

Luxurious speakers equipped with neodymium magnets and treated paper cones.

Ultra-shallow woofers (only 38mm thick) with reversed motor structure, grilles and protective fabrics to prevent dust in the gap.

Comes with tweeter brackets and all necessary passive x-overs.

### Dimensions

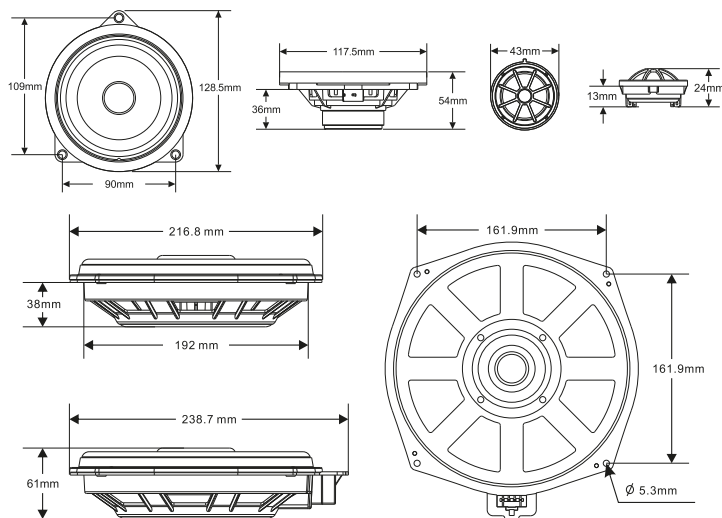

### Connections

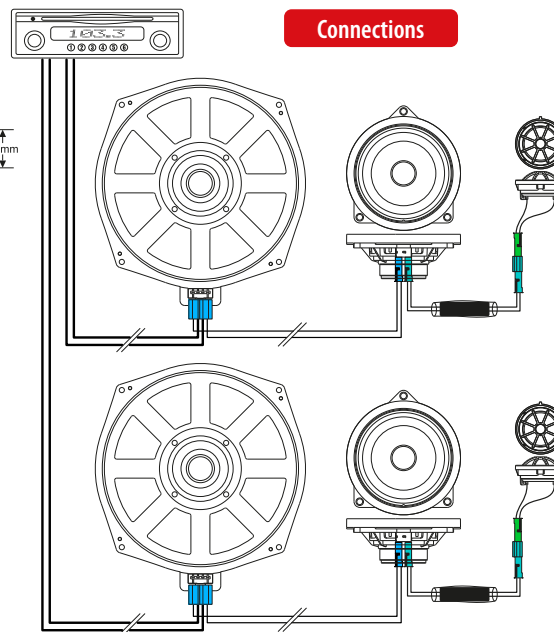

### Compatibility

- BMW : F06 F12 F13 F20 F21 F22 F23 F25 F26 F30 F31 F32 F33 F34 F36 F39 F40 F44 F45 F46 F48 F49 F80 F82 F83 F87 G01 G02 G05 G06 G11 G12 G20 G21 G22 G23 G28 G30 G31 G32 G80 L15
- Mini : F54 F55 F56 F57 F60

### In the box

- 2x woofers
- 2x midranges
- 2x tweeters
- 2x tweeter supports
- 2x passive x-over (on line)



### Specifications

3-way separate speakers

• Woofers

- Diameter: 8" (20cm)
- Magnet: Neodymium
- Voice Coil Ø: 2" (50.8mm)
- Impedance: 4Ω

• Cone: composite paper

• Frame: ABS + carbon

• Midranges

- Diameter: 4" (10cm)

- Magnet: Neodymium

- Voice Coil Ø: 1" (25.4mm)

- Impedance: 4Ω

- Cone: composite paper

- Frame: ABS + fiberglass

• Tweeters

- Diameter: 1" (25mm)

- Magnet: Neodymium

- Voice Coil Ø: 1" (25.4mm)

- Impedance: 4Ω

- Cone: silk dome

- Frame: ABS

• RMS power: 150W

• Peak power: 450W

• Sensitivity: 94.0dB/2.83v/1m

• Impedance: 4Ω

• Response: 22Hz - 25000Hz

